

---

# Capacity Design and Seismic Performance of Multi-Storey Precast Structures

**Fabio Biondini\*** — **Giandomenico Toniolo\*** — **Georgios Tsionis\*\***

*\*Department of Structural Engineering, Politecnico di Milano  
P.za L. da Vinci, 32 – 20133 Milan, Italy*

*biondini@stru.polimi.it  
toniolo@stru.polimi.it*

*\*\*ELSA Laboratory, Joint Research Centre, European Commission  
Via E. Fermi, 2749 – 21027 Ispra (VA), Italy  
george.tsionis@jrc.it*

---

*ABSTRACT. The seismic design of multi-storey precast structures is at present not covered by specific provisions of the European seismic codes. To fill such gap, capacity design criteria for multi-storey precast concrete frames with hinged beams are presented. Based on the same approach prescribed by the codes for monolithic cast-in-place frames, a distribution of floor forces and a value of behaviour factor are assumed to perform a static linear analysis of the structure. A parametric study aimed to validate the design method is carried out by varying, within the range of practical interest, the main design parameters such as the number of storeys, the mass-over-stiffness ratios and the stiffness characteristics of the columns. The results of dynamic modal analyses and non linear static analyses show that the proposed method can safely be applied to ordinary multi-storey concrete precast frames characterized by structural regularity and limited flexibility.*

*KEYWORDS. Precast structures, capacity design, behaviour factor, seismic performance.*

---

## 1. Introduction

The seismic performance of precast concrete structures has been extensively investigated over the last decade within two European research projects (Ecoleader 2001-2003, Growth 2002-2006). Probabilistic numerical analyses and pseudodynamic experimental tests on full scale prototypes have been carried out to demonstrate that the seismic design of precast frames with hinged beams can be based on the criteria adopted for cast-in-place frames, provided that early brittle failures of the joint connections are avoided by a proper capacity design (Biondini and Toniolo 2009). In particular, the results of this investigation showed that in order to achieve a good seismic behaviour with high dissipation capacity, it is not necessary to orient the design of precast structures with hinged beams towards the emulation of cast-in-place structures with monolithic connections. With appropriate dimensioning of members and connections, hinged precast structures are able to provide good seismic performance as monolithic cast-in-place structures.

Specific capacity design criteria are however needed for multi-storey precast systems since, with respect to the cast-in-place solution, the hinged connections between beams and columns modify the internal stresses and, consequently, the ratios of dimensions among members. At present, the seismic design of this type of multi-storey precast structures is not covered by the European seismic code (Eurocode 8, CEN-EN 1998-1). To fill such gap, capacity design criteria for multi-storey precast concrete frames with hinged beams, such as the structures shown in Figure 1, are presented (Biondini *et al.* 2004).



**Figure 1.** *Precast multi-storey frame structures during erection.*

The proposed design method is based on the same approach prescribed by the codes for monolithic cast-in-place frames (CEN-EN 1998-1). A linear distribution of floor forces, able to approximately reproduce the contribution of the first vibration mode, and a value of behaviour factor, properly chosen to comply with the expected ductility capacity of the selected collapse mechanism, are assumed to perform a static linear analysis of the structure. The results of this analysis are used to design the critical cross-sections of the columns at the storey base and, according to specific capacity design criteria, the remaining part of the columns and the beam-column connections.

To validate the proposed method, the actual contribution of the higher vibration modes, as well as the actual ductility capacity of the structure, need to be verified. To this aim, a parametric study on a set of structural solutions covering the field of practical interest is carried out by varying the main design parameters such as the number of storeys, the mass-over-stiffness ratios and the stiffness characteristics of the columns (Biondini *et al.* 2004, 2008). For this set of structures the contributions of the vibration modes in terms of column bending moments and forces in the beam-column connections are evaluated by dynamic modal analyses. Moreover, the displacement ductility of these structures when designed according to the proposed method is estimated by means of non linear static “push-over” analyses. The results show that, with proper safety factors able to cover the uncertainty of the design model, the proposed method can safely be applied to ordinary multi-storey concrete precast frames characterized by structural regularity and limited flexibility.

## 2. Base shear and floor forces

For seismic design of a frame with  $i=1, \dots, n$  storeys, a proper set of floor forces  $F_i$ , equivalent to the effects of the seismic motion, is required to perform a static linear analysis. With reference to the scheme shown in Figure 2, a linear variation with the heights  $z_i$  of the floor forces  $F_i$  is assumed:

$$F_i = \frac{z_i W_i}{\sum_{j=1}^n z_j W_j} F \quad (1)$$

where  $W_i$  is the seismic weight of the  $i$ -th storey, and  $F$  is the total seismic force at the base of the structure. The total base shear  $F$  can be evaluated as follows:

$$F = \frac{\alpha_g \beta_e(T_1)}{q} W \quad (2)$$

where  $\alpha_g$  is the design peak ground acceleration ( $g$  units),  $\beta_e(T_1)$  is the elastic response spectrum shape function computed for the first vibration period  $T_1$  of the structure,  $q$  is the behaviour factor accounting for the ductility and energy dissipation resources which attenuate the seismic effects, and  $W = \sum_{i=1, n} W_i$ . A proper value of the first vibration period  $T_1$  and behaviour factor  $q$  are required to evaluate the base shear  $F$ .

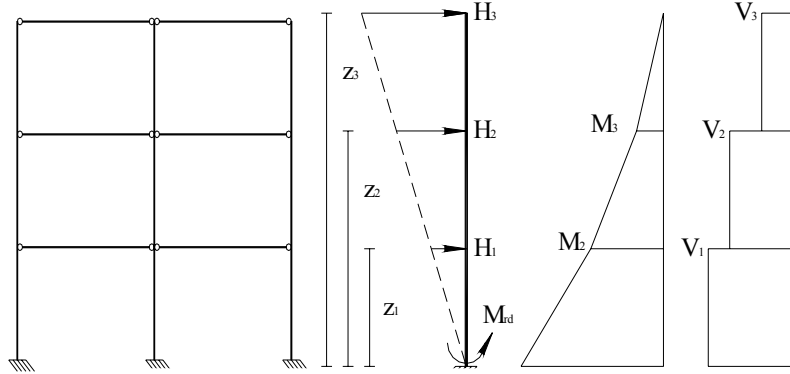

**Figure 2.** Distribution of floor forces, bending moments, and shear forces for a multi-storey frame with hinged beams.

### 3. Modal analysis and vibration period

The evaluation of the first vibration period  $T_1$  requires a dynamic modal analysis of the structure. In most cases of practical interest, multi-storey precast frames are characterized by regular geometry with columns having the same stiffness variation over the storey height. For such cases, modal analysis can be efficiently developed by using either a general procedure referred to a reduced set of degree of freedoms, or a simplified procedure based on an equivalent single degree of freedom system.

#### 3.1. General procedure

For frame systems with regular geometry and hinged beams with negligible axial flexibility, the unknowns of the modal dynamic analysis are the displacements  $d_i$  and rotations  $\varphi_i$  at the  $i=1, \dots, n$  storey heights  $z_i$ , as shown in Figure 3. The rotation  $\varphi_n$  at the upper storey is also considered as unknown for the sake of generalization. By neglecting the rotational inertia of the seismic masses  $m_i = W_i/g$ , the following two sets of  $n$  equations hold for the free vibration of the system with natural frequency  $\omega = 2\pi/T$ :

$$k_i^r \varphi_{i-1} + (k_i^a + k_{i+1}^a) \varphi_i + k_{i+1}^r \varphi_{i+1} + k_i^u d_{i-1} + (-k_i^u + k_{i+1}^u) d_i - k_{i+1}^u d_{i+1} = 0 \quad (3)$$

$$-k_i^u \varphi_{i-1} + (-k_i^u + k_{i+1}^u) \varphi_i + k_{i+1}^u \varphi_{i+1} - k_i^v d_{i-1} + (k_i^v + k_{i+1}^v) d_i - k_{i+1}^v d_{i+1} - \omega^2 m_i d_i = 0 \quad (4)$$

with:

$$k_i^a = \sum_{j=1}^m k_{ij}^a \quad k_i^r = \sum_{j=1}^m k_{ij}^r \quad k_i^v = \sum_{j=1}^m k_{ij}^v \quad k_i^u = \sum_{j=1}^m k_{ij}^u \quad (5)$$

and where the stiffness coefficients of column  $j$  at storey  $i$  can be related to the cross-sectional bending stiffness  $k_{ij}$  by neglecting axial and shear flexibility:

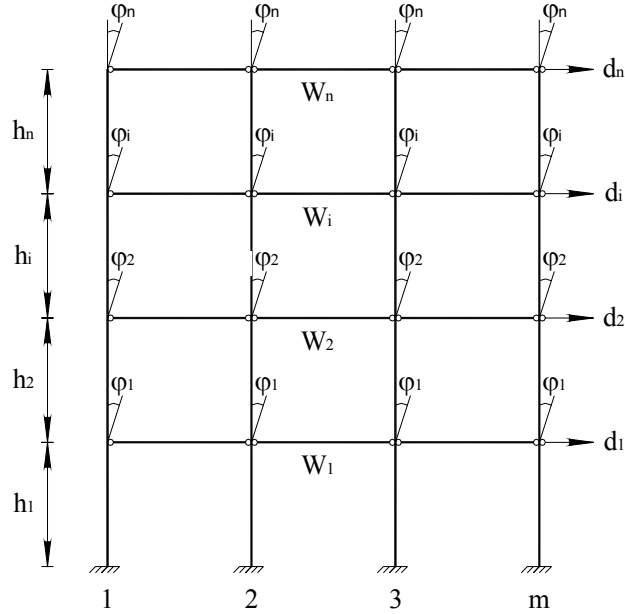

**Figure 3.** Kinematic model for a regular multi-storey frame with hinged beams.

$$k_{ij}^a = \frac{4k_{ij}}{h_i} \quad k_{ij}^r = \frac{2k_{ij}}{h_i} \quad k_{ij}^v = \frac{12k_{ij}}{h_i^3} \quad k_{ij}^u = \frac{6k_{ij}}{h_i^2} \quad (6)$$

The coefficients  $k_{ij}$  can be computed with reference to the inertia moment of the cracked cross-section (CEN-EN 1998-1, 2004).

The equilibrium equations can be written in matrix form as follows:

$$\left( \begin{bmatrix} \mathbf{A}_{11} & \mathbf{A}_{12} \\ \mathbf{A}_{12}^T & \mathbf{A}_{22} \end{bmatrix} - \omega^2 \begin{bmatrix} \mathbf{0} & \mathbf{0} \\ \mathbf{0} & \mathbf{M} \end{bmatrix} \right) \begin{bmatrix} \Phi \\ \Delta \end{bmatrix} = \begin{bmatrix} \mathbf{0} \\ \mathbf{0} \end{bmatrix} \quad (7)$$

where  $\mathbf{A}_{11}$ ,  $\mathbf{A}_{22}$ , and  $\mathbf{A}_{12}$ , are  $n \times n$  square matrices of stiffness coefficients,  $\mathbf{M}$  is the diagonal matrix of the  $n$  storey masses  $m_i$ ,  $\Phi$  and  $\Delta$  are the  $n$ -vectors of the unknown rotations  $\varphi_i$  and displacements  $d_i$ , respectively. The vector  $\Phi$  can be condensed to obtain the following  $n$  equations in terms of the vector  $\Delta$ :

$$(\mathbf{B} - \omega^2 \mathbf{M}) \Delta = \mathbf{0} \quad (8)$$

with:

$$\mathbf{B} = \mathbf{A}_{22} - \mathbf{A}_{12}^T \mathbf{A}_{11}^{-1} \mathbf{A}_{12} \quad (9)$$

The  $k=1, \dots, n$  eigenvalues  $\omega_k=2\pi/T_i$ , with  $i=(n-k+1)$ , are obtained as the  $n$ -roots of the following equation:

$$\det(\mathbf{B} - \omega^2 \mathbf{M}) = 0 \tag{10}$$

The  $n$  eigenvectors representing the modal shapes can also be obtained as follows:

$$\Delta_k = \mathbf{C}_k^{-1} \mathbf{u}_k \tag{11}$$

$$\Phi_k = -\mathbf{A}_{11}^{-1} \mathbf{A}_{12} \Delta_k \tag{12}$$

with:

$$\mathbf{C}_k = \mathbf{B} - \omega_k \mathbf{M} = \begin{bmatrix} c_{11} & c_{12} & c_{1i} & c_{1n} \\ c_{21} & c_{22} & c_{2i} & c_{2n} \\ \hline 0 & 0 & 1 & 0 \\ \hline c_{n1} & c_{n1} & c_{ni} & c_{nn} \end{bmatrix} \quad \mathbf{u}_i = \begin{bmatrix} u_1 \\ u_2 \\ \hline u_i \\ \hline u_n \end{bmatrix} = \begin{bmatrix} 0 \\ 0 \\ \hline 1 \\ \hline 0 \end{bmatrix} \tag{13}$$

### 3.2. Simplified procedure

The first vibration period  $T_1$  of a regular frame structure, such as the  $2n$ -degree of freedom system shown in Figure 3, with  $n$  storeys,  $m$  columns, and total height  $h$ , can be related to the vibration period  $T_0$  of an equivalent single degree of freedom system having the cross-sectional bending stiffness  $k_{1j}$  of the columns  $j=1, \dots, m$  at the first storey and the total seismic weight  $W$  concentrated at  $z_n=h$ :

$$T_1 = \psi \left( 2\pi \sqrt{\frac{W/g}{\sum_{j=1}^m 3k_{1j}/h^3}} \right) = \psi T_0 \tag{14}$$

where the correlation coefficient  $\psi=\psi(n)$  depends on the distribution of the heights  $h_i=(z_i-z_{i-1})$ , weights  $W_{i_s}$  and stiffness  $k_{ij}$  over the storeys  $i=1, \dots, n$ . The coefficient  $\psi=\psi(n)$  is given in Table 1 under the assumption of equal storey heights  $h_i$ , equal storey weights  $W_{i_s}$  and columns with (a) constant stiffness at each storey, or  $k_{ij}=k_{1j}$ , and (b) stiffness linearly decreasing with the storey level, or  $k_{ij}=k_{1j}(n-i+1)/n$ .

$n$	1	2	3	4	$\infty$
(a) Constant	1.00	0.74	0.66	0.62	0.49
(b) Variable	1.00	0.78	0.71	0.67	0.57

**Table 1.** Coefficient  $\psi=\psi(n)$  for frames with  $i=1, \dots, n$  storeys and  $j=1, \dots, m$  columns with (a) constant stiffness  $k_{ij}=k_{1j}$ , and (b) variable stiffness  $k_{ij}=k_{1j}(n-i+1)/n$ .

#### 4. Collapse mechanism and behaviour factor

For structural members in bending, such as beams and columns, the curvature ductility  $\mu_\phi$  of the cross-section is measured by the ratio between the ultimate curvature  $\chi_u$  and the yielding curvature  $\chi_y$ :

$$\mu_\phi = \frac{\chi_u}{\chi_y} = 1 + \frac{\chi_p}{\chi_y} \quad (15)$$

where  $\chi_p = \chi_u - \chi_y$  denotes the plastic curvature. For concrete cross-sections a curvature ductility  $\mu_\phi \cong 7 \div 8$  can generally be achieved if a suitable reinforcing steel is used (Saisi and Toniolo 1998).

With the same criteria, the displacement ductility  $\mu_\delta$  of a column is measured by the ratio between the ultimate displacement  $\delta_u$  and the yielding displacement  $\delta_y$ :

$$\mu_\delta = \frac{\delta_u}{\delta_y} = 1 + \frac{\delta_p}{\delta_y} \quad (16)$$

The yielding displacement  $\delta_y$  and plastic displacement  $\delta_p = \delta_u - \delta_y$  can be related to the cross-sectional yielding curvature  $\chi_y$  and plastic curvature  $\chi_p$ , respectively, based on the type of beam-column connections.

With reference to the scheme shown in Figure 4, for columns with hinged beams the following relationships hold (Biondini and Toniolo 2003):

$$\delta_y \cong \frac{\chi_y h^2}{3} \quad (17)$$

$$\delta_p \cong \phi_p h = \chi_p h_p h \quad (18)$$

where  $h$  is the column height,  $h_p$  is the length of the critical zone at the column base where the plastic hinge develops with  $\chi \geq \chi_y$ , and  $\phi_p$  is the plastic hinge rotation.

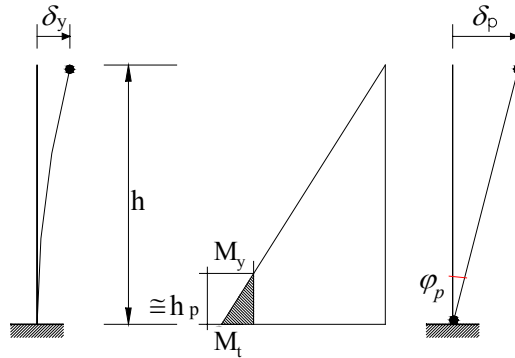

**Figure 4.** Elastic and plastic deformation of concrete columns with hinged beams.

As shown in Figure 4, the plastic hinge length  $h_p$  can be related to the ratio of ultimate moment  $M_t$  versus yielding moment  $M_y$  of the column cross-section. This ratio depends on the ratio of ultimate strength  $f_t$  versus yielding strength  $f_y$  of reinforcing steel, for which a value in the range  $1.15 \leq f_t/f_y \leq 1.35$  is recommended in seismic design to ensure a suitable ductility (CEN-EN 1998-1, Fardis 2008). For an ordinary reinforcing steel with  $M_t/M_y \approx f_t/f_y \cong 1.20$ , a plastic hinge length  $h_p \cong h/6$  is therefore obtained. In this way, the displacement ductility  $\mu_\delta$  of the column can be related to the curvature ductility  $\mu_\phi$  of the cross-section as follows:

$$\mu_\delta \cong \frac{1}{2}(1 + \mu_\phi) \cong 4.0 \div 4.5 \quad (19)$$

The displacement ductility  $\mu_\Delta$  of a structure is measured by the ratio between the ultimate displacement  $d_u$  and the yielding displacement  $d_y$  at the top storey:

$$\mu_\Delta = \frac{d_u}{d_y} = 1 + \frac{d_p}{d_y} \quad (20)$$

where  $d_p = d_u - d_y$  is the plastic displacement. As shown in Figure 5 for a frame with  $n=3$  storeys, the displacement ductility  $\mu_\Delta$  depends on the number  $p \leq n$  of storeys involved in the collapse mechanism (Biondini *et al.* 2004):

$$\mu_\Delta \cong 1 + \frac{p\delta_p}{n\delta_y} = 1 + \frac{p}{n}(\mu_\delta - 1) \leq \mu_\delta \quad (21)$$

where  $\mu_\Delta = \mu_\delta \cong 4.0 \div 4.5$  for  $p=n$ .

For relatively flexible structures with high vibration periods, as those considered in this study, the equal displacement criterion holds, or  $q = \mu_\Delta$  (Pauley and Priestley 1992). Therefore, according to this criterion, a behaviour factor  $q=4.0$  can reliably be assumed for multi-storey precast frames if the activation of collapse mechanisms with  $p < n$  are avoided by a proper capacity design.

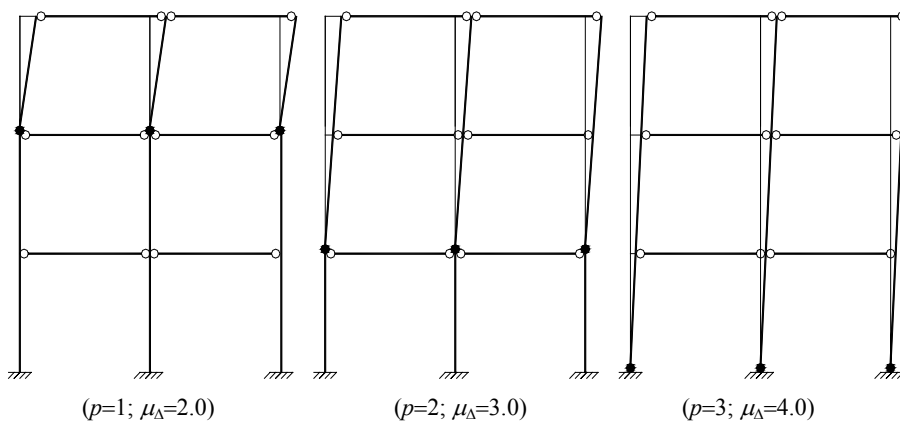

**Figure 5.** Collapse mechanisms for a precast frame structure with  $n=3$  storeys.



### 5. Capacity design criteria

To comply with a global collapse mechanism with  $p=n$  (Figure 5), the critical cross-section at the base of each column has to be designed to achieve the following resistant bending moment  $M_{rd}$ :

$$M_{rd} \geq \lambda \sum_{i=1}^n F_i z_i \quad (22)$$

where  $\lambda$  is the percentage of the floor force  $F_i$  applied to the column in proportion to its stiffness. The remaining part of the column has to be consequently designed for horizontal floor forces  $H_i$  evaluated in terms of the resistant moment  $M_{rd}$ :

$$\sum_{i=1}^n H_i z_i = \gamma_R M_{rd} \quad (23)$$

where  $\gamma_R = \gamma' \gamma''$  is a partial safety factor subdivided into two components,  $\gamma'$  and  $\gamma''$ , which cover, respectively, the possible over-strength of the reinforcing steel and the uncertainty involved in the linear distribution of the floor forces  $F_i$ , as well as in the linear model that has to be assumed to solve the indeterminacy in the evaluation of the floor forces  $H_i$  (Figure 2):

$$H_i = H_n \frac{z_i}{z_n}, \quad i=1, \dots, n-1 \quad (24)$$

Based on this linear model, the following floor forces are obtained:

$$H_i = \gamma_R M_{rd} \frac{z_i}{\sum_{j=1}^n z_j^2}, \quad i=1, \dots, n \quad (25)$$

In this way, the capacity design of the column can be applied both in bending (Figure 2):

$$M_i \geq \sum_{j=i}^n H_j (z_j - z_{i-1}) = \gamma_R M_{rd} \frac{\sum_{j=i}^n z_j (z_j - z_{i-1})}{\sum_{j=1}^n z_j^2}, \quad i=2, \dots, n \quad (26)$$

and shear (Figure 2):

$$V_i \geq \sum_{j=i}^n H_j = \gamma_R M_{rd} \frac{\sum_{j=i}^n z_j}{\sum_{j=1}^n z_j^2}, \quad i=1, \dots, n \quad (27)$$

Finally, to avoid brittle failures of the joints, the beam-column connections at the  $i$ -th storey have to be designed for the corresponding floor force  $H_i$ . For internal columns, the forces  $H'_i$  and  $H''_i$  transferred to the left and right connections, respectively, can be evaluated in proportion to the seismic weights  $W'_i$  and  $W''_i$  of the two corresponding adjacent bays as follows (Figure 6):

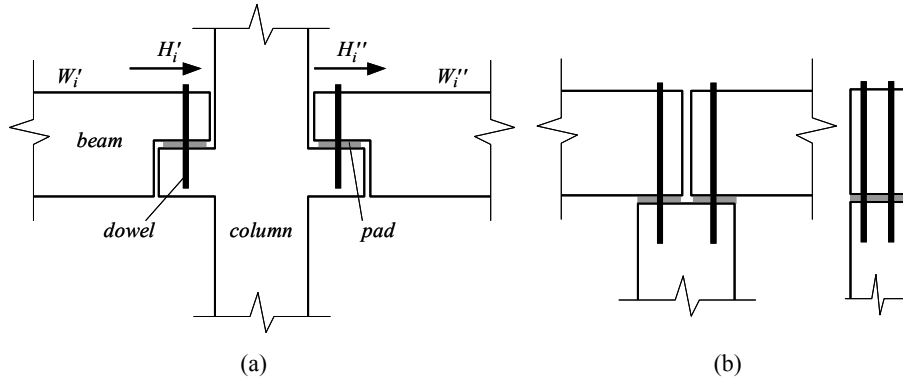

**Figure 6.** Beam-column connections for (a) floors, and (b) roofs.

$$H_i' = \frac{W_i'}{W_i' + W_i''} H_i \quad H_i'' = \frac{W_i''}{W_i' + W_i''} H_i \quad (28)$$

However, the higher vibration modes generate forces in opposite directions at the storey levels which give little contributions to the column moments, but may result in significant stresses at connections. For this reason, it is considered appropriate to design all beam-column connections for the maximum force at the top floor:

$$H \geq H_n = \gamma_R M_{rd} \frac{z_n}{\sum_{i=1}^n z_i^2} \quad (29)$$

This design procedure assumes hinged connections between beams and columns. Since connections are not perfect hinges, bending moments can develop at the joints and lead to an increase of the floor forces. However, for the type of connections shown in Figure 6, such moments are limited by the flexural capacity of the dowels, that is expected to be negligible compared to the column resistant moments. The increase of the floor forces due to the bending moments at the beam-column joints can therefore reliably be covered by adopting a suitable value of the partial safety factor  $\gamma''$ .

## 6. Validation of the design method

A reliable application of the proposed capacity design criteria has to be based on proper values of the partial safety factors  $\gamma'$  and  $\gamma''$ , required to cover the uncertainty associated to both the over-strength of reinforcing steel and the model assumed to evaluate the floor forces, respectively. Moreover, adequate ductility resources are required at both local and global level to comply with the value  $q=\mu_{\Delta}=4.0$  of the behaviour factor.

### 6.1. Steel over-strength

Based on the properties of ordinary reinforcing steel, the possible over-strength due to steel strain hardening can be covered by assuming  $\gamma'=1.25$  (CEN-EN 1998-1). It is worth noting that a value  $\gamma'=1.00$  can however be safely adopted in case the same type of reinforcing steel is used over the column height.

### 6.2. Floor forces

For the type of structures under investigation the influence of the higher modes of vibration may be important and, consequently, the inaccuracy of the hypothesis of linear variation with height of the floor forces needs to be fully covered by the factor  $\gamma''$ . To this aim, a validation of the proposed method is carried out by varying the number  $n$  of storeys, the first vibration period  $T_1$ , and the type of variability over the height  $z_i$  of the cross-sectional bending stiffness  $k_{ij}$  of the columns (Biondini *et al.* 2004). Such parameters have been varied within the range of practical interest as follows:  $n=\{2, 3, 4\}$ ;  $T_1=\{2.50, 1.50, 1.00, 0.75, 0.50 \text{ sec}\}$ ;  $k_{ij}=k_{1j}$  (constant stiffness) and  $k_{ij}=k_{1j}(n-i+1)/n$  (linearly decreasing stiffness). The seismic action is evaluated according to the shape function  $\beta_e(T_1)$  of the elastic response spectrum type 1 for ground category B of Eurocode 8 (CEN-EN 1998-1, 2004).

The results of the parametric analysis are expressed in terms of ratio between the values provided by a response spectrum modal analysis, which takes the contribution of all vibration modes into account, and the values obtained from the proposed design method, which considers the first vibration mode only. Tables 2 and 3 give such ratios for the column bending moments  $M_i$  at the base of storey  $i$ , and the floor forces  $H_i$  at the beam-column connections of storey  $i$ , respectively.

The results listed in Table 2 show that the actual bending moments at the base of the first storey are, in all cases studied, lower than those computed according to the design method. Therefore, the design method is reliable under condition that the integrity of the columns at the upper storeys is assured by a proper capacity design. With this regard, since bending moment ratios larger than one may be obtained in the upper storeys, a proper safety factor  $\gamma''>1$  has to be applied.

$M_i$	(a) Constant stiffness					(b) Variable stiffness				
	$T_1$ [sec]					$T_1$ [sec]				
Storey	2.50	1.50	1.00	0.75	0.50	2.50	1.50	1.00	0.75	0.50
$i$	2.50	1.50	1.00	0.75	0.50	2.50	1.50	1.00	0.75	0.50
2	1.27	1.00	0.94	0.91	0.90	1.26	0.99	0.94	0.91	0.90
1	0.91	0.86	0.84	0.83	0.83	0.97	0.85	0.83	0.82	0.82
3	<b>1.77</b>	1.13	0.99	0.91	0.88	<b>1.71</b>	1.12	0.98	0.91	0.91
2	0.88	0.83	0.82	0.82	0.82	0.84	0.81	0.81	0.81	0.81
1	0.89	0.81	0.79	0.78	0.78	0.92	0.80	0.78	0.78	0.77
4	<b>2.07</b>	1.23	1.03	0.91	0.87	<b>2.05</b>	0.84	1.21	1.22	1.22
3	<b>1.56</b>	1.23	1.17	1.13	1.12	<b>1.41</b>	1.09	1.17	1.17	1.17
2	0.79	0.78	0.78	0.78	0.78	0.77	0.76	0.76	0.76	0.76
1	0.86	0.78	0.77	0.76	0.75	0.88	0.73	0.76	0.77	0.77

**Table 2.** Ratio between actual value and design value of the bending moments  $M_i$  at the base of storey  $i$ : (a) constant stiffness  $k_{ij}=k_{1j}$ ; (b) variable stiffness  $k_{ij}=k_{1j}(n-i+1)/n$ .

$H_i$	(a) Constant stiffness					(b) Variable stiffness				
	Storey	$T_1$ [sec]					$T_1$ [sec]			
$i$	2.50	1.50	1.00	0.75	0.50	2.50	1.50	1.00	0.75	0.50
2	1.11	0.88	0.83	0.80	0.79	1.10	0.86	0.82	0.79	0.79
1	<b>2.54</b>	1.24	0.85	0.53	0.38	<b>2.71</b>	<b>1.32</b>	0.89	0.58	0.39
3	<b>1.55</b>	0.99	0.87	0.79	0.77	<b>1.50</b>	0.98	0.86	0.80	0.77
2	<b>2.20</b>	1.08	0.77	0.56	0.46	<b>2.44</b>	1.19	0.83	0.60	0.46
1	<b>2.06</b>	0.92	0.60	0.37	0.24	<b>2.15</b>	0.91	0.57	0.37	0.24
4	<b>1.81</b>	1.08	0.90	0.80	0.76	<b>1.80</b>	1.07	0.90	0.81	0.76
3	<b>1.69</b>	0.86	0.66	0.55	0.50	<b>2.09</b>	1.02	0.73	0.58	0.50
2	<b>2.22</b>	1.10	0.75	0.48	0.35	<b>2.29</b>	1.07	0.72	0.49	0.34
1	<b>1.59</b>	0.70	0.44	0.27	0.18	<b>1.61</b>	0.67	0.41	0.26	0.17

**Table 3.** Ratio between actual value and design value of the floor forces  $H_i$  at the beam-column connections of storey  $i$ : (a) constant stiffness  $k_{ij}=k_{1j}$ ; (b) variable stiffness  $k_{ij}=k_{1j}(n-i+1)/n$ .

For structures with vibration periods  $T_1 \leq 2.0$  sec, the results given in Table 2 show that a value  $\gamma''=1.30$  allows to cover the deviation of the design method in the estimation of the column bending moments. As shown in Table 3, this value allows to also cover the deviation in the estimation of the floor forces at the beam-column connections. Moreover, in most cases the safety margins associated to  $\gamma''=1.30$  seem to be adequate to include the effects of the neglected bending moments at the beam-column joints, as well as the uncertainty of the model used for the parametric analysis. Further investigations are however needed to confirm these results.

On the contrary, for structures with  $T_1 > 2.0$  sec the effects of the higher modes leads to exceeding the value  $\gamma''=1.30$  for both bending moments and floor forces. The design method is therefore not applicable to these structures.

### 6.3. Displacement ductility capacity

A further parametric study is carried out to investigate the displacement ductility capacity of multi-storey precast frames designed according to the proposed method (Biondini *et al.* 2008). The same variability of the design parameters  $n$ ,  $T_1$ , and  $k_{ij}$ , is considered. The structures are designed by assuming storey weights  $W_i=1.2$  MN, storey heights  $h_i=4.0$  m, design peak ground acceleration  $\alpha_g=0.35$ , and behaviour factor  $q=4.0$ .

The columns are designed with the same square cross-section and by assuming concrete class C30 and steel class S500. The main design parameters are listed in Tables 4 and 5, where  $F'=\lambda F$  is the total column base shear,  $M_{sd}$  is the column bending moment at the base of the first storey,  $b$  is the size of the square cross-section of the columns at the base of the first storey, and  $A_s$  is the area of longitudinal reinforcement. The minimum amount of reinforcement prescribed by the code,  $\rho_{\min}=A_{s,\min}/b^2=0.01$ , is adopted for all columns (CEN-EN 1998-1, 2004), since it is higher than the minimum amount required by design. The size  $b$  is chosen so as to obtain the desired value of  $T_1$ , computed by assuming a stiffness  $k_{1j}$  of the cracked cross-section equal to 50% of the stiffness of the uncracked cross-section.

	2-storey frame				3-storey frame		4-storey frame
	2.50	1.50	1.00	0.75	2.50	1.50	2.50
$T_1$ [sec]	2.50	1.50	1.00	0.75	2.50	1.50	2.50
$F'$ [kN]	34	70	105	140	50	106	67
$M_{sd}$ [kNm]	224	469	699	933	470	986	806
$b$ [cm]	43	56	68	81	61	79	79
$A_s$ [cm <sup>2</sup> ]	18.6	30.9	46.4	66.3	37.3	62.1	62.2

**Table 4.** Design parameters for columns with constant stiffness  $k_{ij}=k_{1j}$ .

	2-storey frame				3-storey frame		4-storey frame
	2.50	1.50	1.00	0.75	2.50	1.50	2.50
$T_1$ [sec]	2.50	1.50	1.00	0.75	2.50	1.50	2.50
$F'$ [kN]	34	70	105	140	50	106	67
$M_{sd}$ [kNm]	224	469	699	933	470	986	806
$b$ [cm]	44	57	70	84	63	82	82
$A_s$ [cm <sup>2</sup> ]	19.6	32.6	48.9	69.9	40.1	66.8	67.2

**Table 5.** Design parameters for columns with variable stiffness  $k_{ij}=k_{1j}(n-i+1)/n$ .

The size  $b$  obtained for  $n=2$  with  $T_1 < 0.75$  sec,  $n=3$  with  $T_1 < 1.50$  sec, and  $n=4$  with  $T_1 < 2.50$  sec is out from the range of practical interest. These cases are therefore not considered in the parametric analysis.

Non-linear static analyses under imposed horizontal displacement at the top of the structures are performed by modelling the critical zone at the base of the columns with a fibre beam model implemented within the code Cast3m (Guedes *et al.*, 1994). The concrete stress-strain law in compression is modelled by a parabolic curve up to the peak stress, followed by a softening straight line with slope properly defined to account for confinement (Mander *et al.*, 1988). An elastic-perfectly plastic stress-strain law is used for the reinforcing steel. Linear elastic behaviour is assumed for the remaining parts of the columns.

The capacity curves, i.e. the total base shear force  $F$  versus the displacement  $d$  at the top of the structure, are shown in Figures 7 and 8. These curves allow to assess the displacement ductility capacity as  $\mu_\Delta = d_m/d_y$ . The yielding displacement  $d_y$  is estimated based on an equivalent bilinear elastic-plastic model with equal strength and equal dissipated energy up to the displacement at the peak force of the actual capacity curve. The maximum displacement  $d_m$  is associated to the point of the capacity curve where the total base shear force  $F$  drops to 80% of the peak value.

The computed values of displacement ductility  $\mu_\Delta$  are given in Table 6. Based on these results, a value of the behaviour factor  $q=4.0$  is found to be appropriate for structures with first vibration period  $T_1 \leq 2.0$  sec. With this regard, it is worth noting that the high values of displacement ductility obtained for structures with  $T_1 < 1.0$  sec seem to be consistent with the equal energy rule ( $q = \sqrt{2\mu_\Delta - 1}$ ), instead of the equal displacement rule ( $q = \mu_\Delta$ ). For structures with  $T_1 > 2.0$  sec, the design method does not allow to obtain adequate values of displacement ductility. Consequently, it is confirmed that the proposed method is not applicable to structures with  $T_1 > 2.0$  sec.

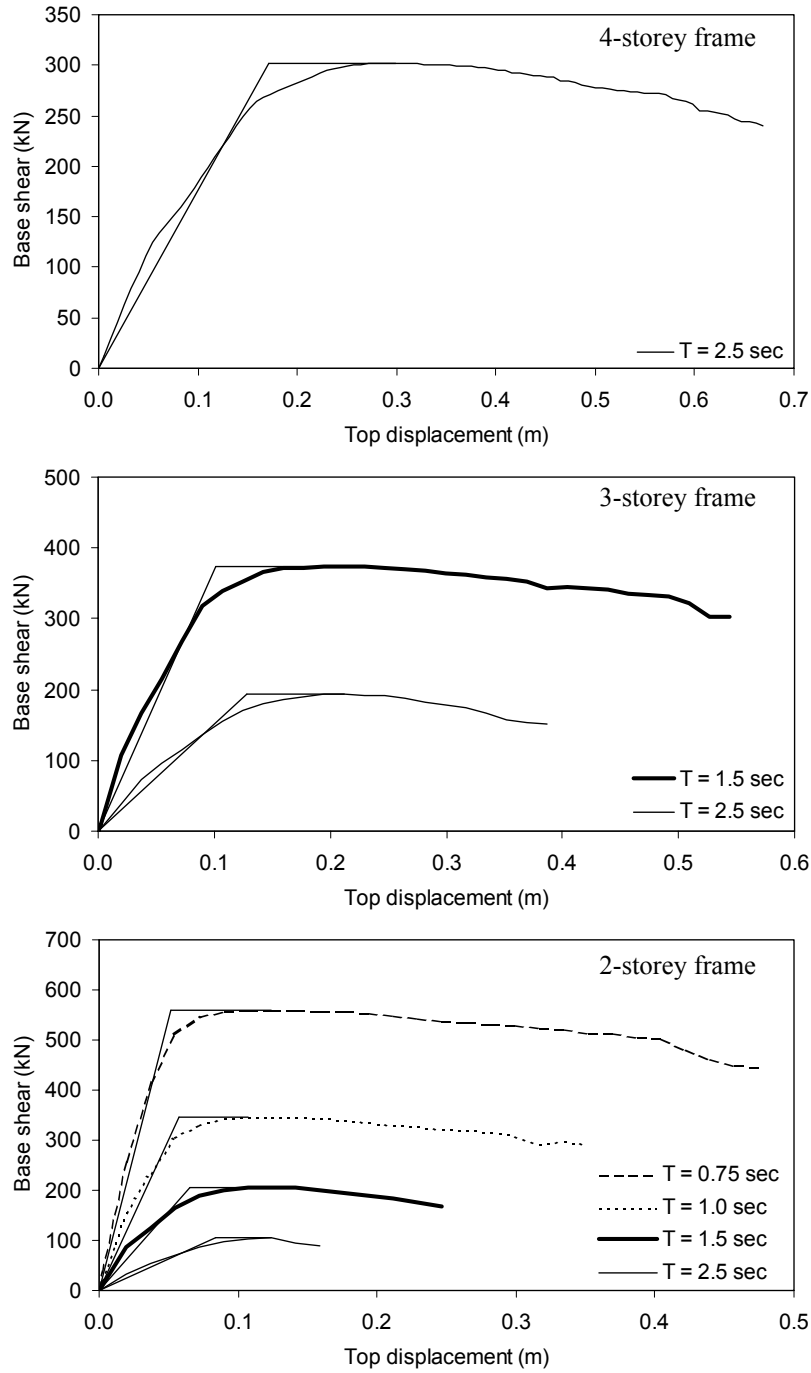

**Figure 7.** Capacity curves for frames with constant stiffness  $k_{ij}=k_{1j}$ .

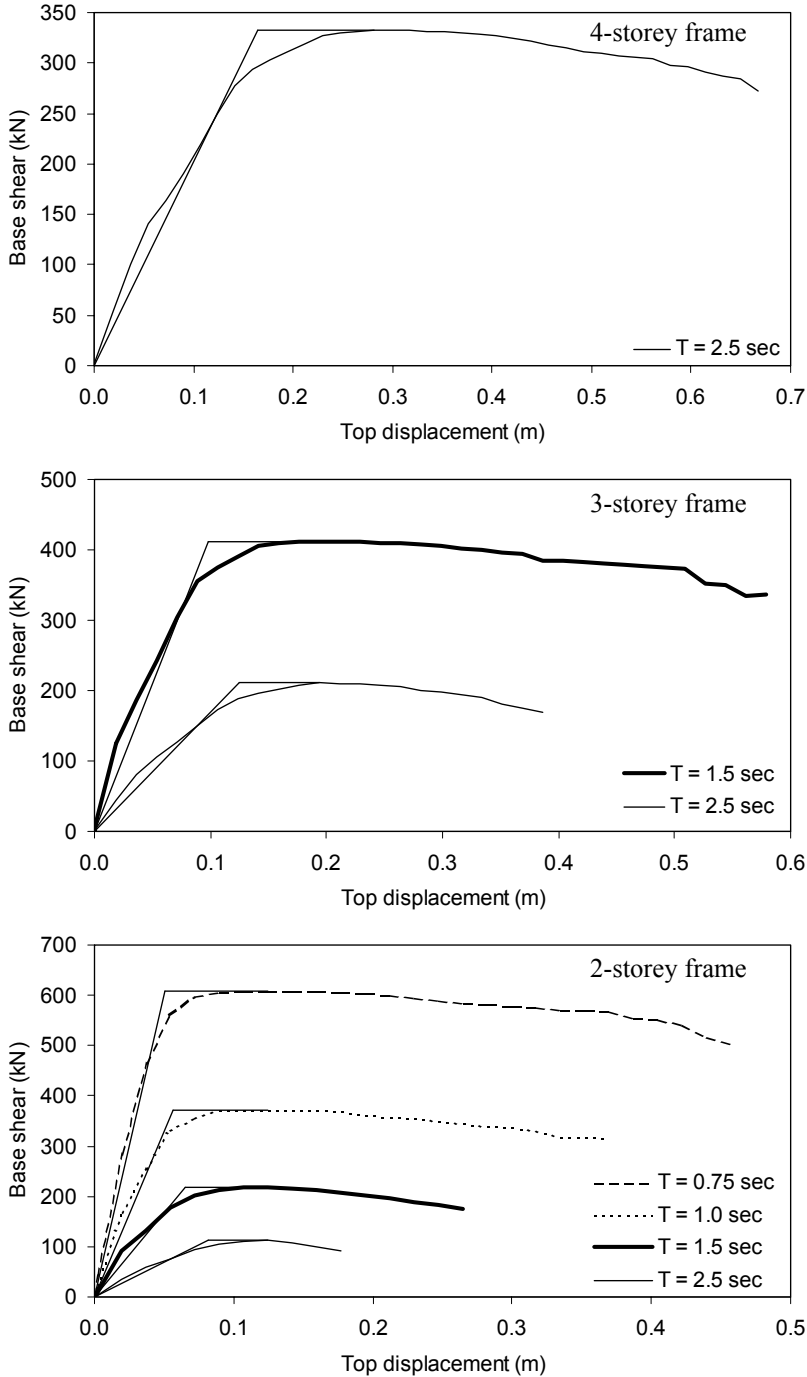

Figure 8. Capacity curves for frames with variable stiffness  $k_{ij}=k_1/(n-i+1)/n$ .

	2-storey frame				3-storey frame		4-storey frame
	T <sub>1</sub> (sec)				T <sub>1</sub> (sec)		T <sub>1</sub> (sec)
	2.50	1.50	1.00	0.75	2.50	1.50	2.50
Constant stiffness	1.9	3.8	6.2	9.1	3.0	5.4	3.9
Variable stiffness	2.2	4.1	6.6	9.1	3.1	5.9	4.0

**Table 6.** Displacement ductility capacity  $\mu_{\Delta}$ .

Clearly, to generalize such results the seismic performance of this type of multi-storey frames should be investigated by means of step-by-step non-linear dynamic analyses for a sufficiently large set of accelerograms. However, despite the necessity of further investigations, the obtained results indicate that with appropriate dimensioning of members and connections, hinged precast structures are able to provide good seismic performance as monolithic cast-in-place structures.

## 7. Conclusions

Based on the same criteria prescribed by the seismic codes for monolithic cast-in-place structures, a method for the capacity design of multi-storey precast concrete frames with hinged beams has been presented. The proposed method has been validated by means of dynamic modal analyses and non linear static analyses. The results demonstrated that the design method can be safely applied to regular structures with first vibration period  $T_1 \leq 2.0$  sec, under condition that a suitable partial safety factor is adopted. It is worth noting that this safety factor may lead to an over-dimensioning of the less flexible structures. However, in such cases a better proportioning of the columns and their connections to beams can be achieved with reference to the distribution of stresses provided by a dynamic modal analysis.

### Acknowledgements

The present study has been developed within the European research projects ECOLEADER (Contract No. HPRI-CT-1999-00059), and GROWTH (Contract No. G6RD-CT-2002-70002).

## 8. References

- Biondini, F. and Toniolo, G., Seismic behaviour of concrete frames: experimental and analytical verification of Eurocode 8 design rules, *fib Symposium: Concrete Structures in Seismic Regions*, Athens, Greece, May 6-9, 2003.
- Biondini F., Toniolo G., and Tsionis G., Seismic design of multi-storey precast structures with hinged frames, *Studies and Researches*, **25**, 2004, 57-94.
- Biondini F., Toniolo G., and Tsionis G., Seismic design criteria for multi-storey precast structures, *14<sup>th</sup> World Conference on Earthquake Engineering (WCEE)*, Beijing, China, October 12-17, 2008, Paper 05-03-0024.



- Biondini F., and Toniolo G., Probabilistic calibration and experimental validation of the seismic design criteria for one-storey concrete frames, *Journal of Earthquake Engineering*, **13**, 2009, 426–462.
- CEN-EN 1998-1, *Eurocode 8: Design of Structures for Earthquake Resistance. Part 1: General rules, seismic actions and rules for buildings*, European Committee for Standardization, Brussels, 2004.
- Fardis, M.N., Earthquake-resistant design of concrete buildings according to EN1998-1, *Eurocodes: Background and Applications*, Brussels, Belgium, February 18, 2008.
- Guedes J., Pegon P., and Pinto A.V., *A Fibre/Timoshenko beam element in CASTEM 2000*, Special publication I.94.31, Joint Research Centre, Ispra, Italy, 1994.
- Mander J.B., Priestley M.J.N., and Park R., Theoretical stress–strain model for confined concrete, *Journal of Structural Engineering*, ASCE, **114**(8), 1988, 1804-1826.
- Pauley, T., and Priestley, M.J.N., *Seismic Design of Reinforced Concrete and Masonry Buildings*, John Wiley & Sons, 1992.
- Saisi, A., and Toniolo, G., Precast r.c. columns under cyclic loading: an experimental program oriented to EC8, *Studi e Ricerche*, School for Concrete Structures “F.lli Pesenti”, Politecnico di Milano, **19**, 1988, 373–414.